

R134a

ECO COOLER

AIR COOLED CHILLER

HIGH EFFICIENT MODEL

50Hz

150 kW – 2000 kW

2022

ECO COOLER
AIR CONDITIONER

MULTI STAGE EVAPORATIVE COOLING





Special Public places
Commercial, Office, Hospital, Restaurant,
Coffee shop & Etc .

ECO COOLER

AIR CONDITIONER

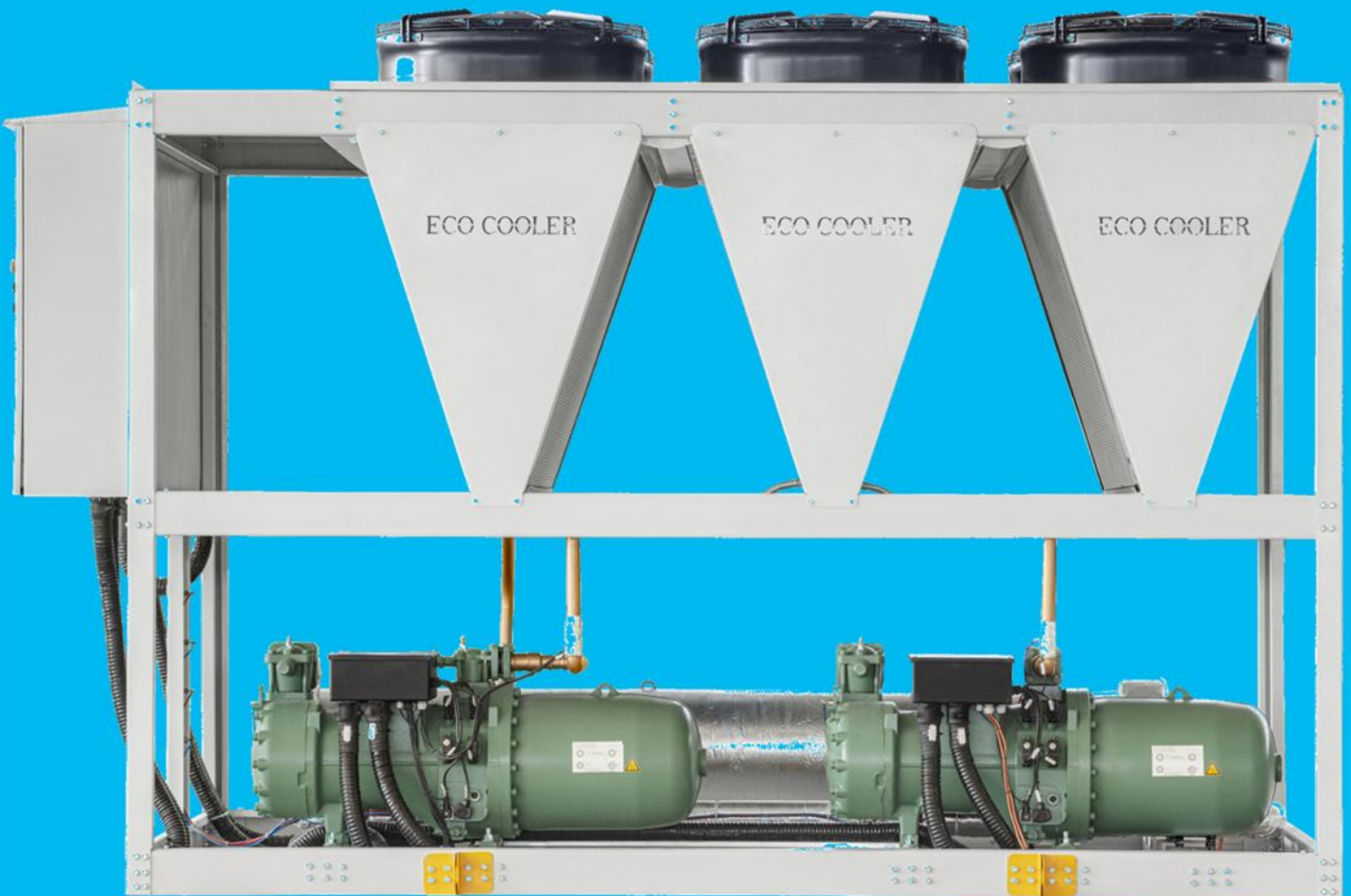



ECO COOLER

Table of Contents

INTRODUCTION	7
NOMENCLATURE	7
FEATURES AND BENEFITS	8
STANDARD SPECIFICATIONS	9
OPTIONAL FEATURES	15
TECHNICAL DATA	16
PERFORMANCE DATA TABLES	19
UNIT DIMENSIONS	24
Typical electrical wiring diagram	36
TYPICAL WIRING DIAGRAM	37

INTRODUCTION

Eco Cooler connection with customer is permanent and does not lead to sell units. Our motto is making the best environment for people to build a better world to live.

Eco Cooler Air cooled water chillers **EACH** series designed to be suitable for all weather conditions, from cold to moderate to hot climates, the various environment, from residential building to industrial sites with polluted environment. Optimum performance, high efficiency, low power consumption, easy installation and low noise operations are the features of the EACH chillers.

EACH series cooling capacities are available from 45 TR (158 kW) to 430 TR (1512 kW). Models are in two categories of STANDARD (for cold and moderate climates) and HIGH EFFICIENT (for hot and tropical climates) conditions.

NOMENCLATURE

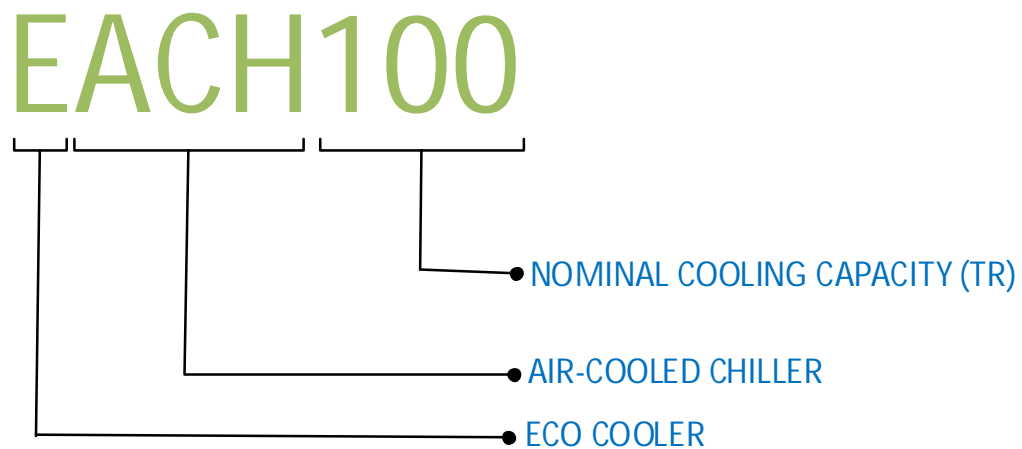

FEATURES AND BENEFITS

- Optimized energy efficiency both at full and part load conditions
- Low operating sound levels are achieved by the latest compressor and fan design
- Stepped and Stepless screw compressor with professional control system to minimize energy consumption and optimize the unit performance.
- Compact design for minimized installation space and small footprint
- One, two, three or four truly independent refrigerant circuits for outstanding reliability
- Using microchannel technology for condenser with higher corrosion resistance and longer life and 30% refrigerant charge compared to traditional solutions.
- Structure and base in hot-dip galvanized steel with electrostatic powder painting.
- Electrical expansion valve: quickly and precisely adapts to the effective load required.
- Connectable to Building Management Systems (BMS) via MODBUS, BACNet and CANBUS protocols.



STANDARD SPECIFICATIONS

SEMI HERMETIC SCREW COMPRESSOR

EACH compressors features mechanical capacity control, which enables very good efficiency and simple system integration. It features mechanical capacity control, which enables very good efficiency and simple system integration. Screw Compressors are equipped to solenoid valve for stepped or stepless capacity control, suction and discharge shut-off valve, oil sight glass, check valve in discharge gas outlet, oil fill/drain service valve, directly flanged on three stage oil separator, robust axial bearings in tandem configuration, internal pressure relief valve as a burst protection and manual lock-out electronic protection system for thermal motor winding temperature, phase reversal, discharge gas temperature protection controls.

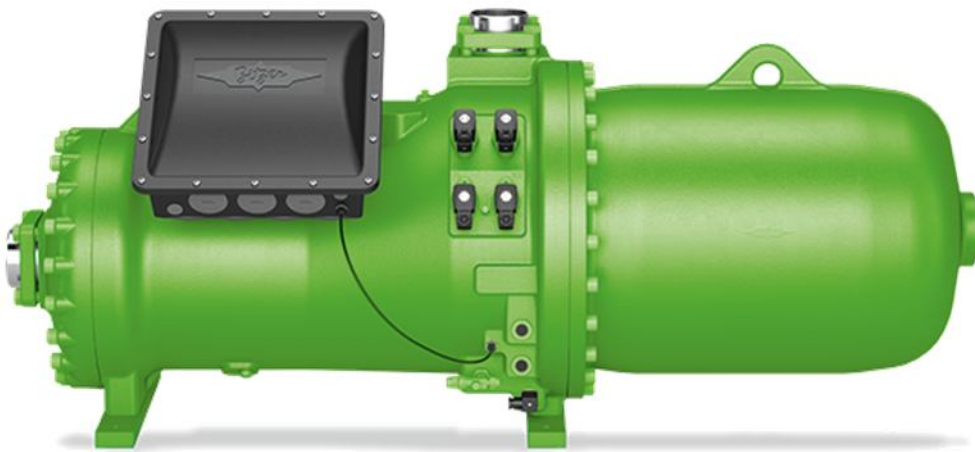

STANDARD SPECIFICATIONS

SHELL AND TUBE EVAPORATOR

The evaporator is a high efficiency DX shell & tube heat exchanger design with inner grooved copper tubes roller expanded into the tube sheet. evaporators are tested with a refrigerant side of 30 bars and a water side of 10 bars. Helium leak test is a standard test for evaporators. A guarantee is offered against coolant leak for up to 2 gr/year. Tests are performed at various pressure levels for multi circuit evaporator and prevention of leakage between circuits is guaranteed. Water connections are grooved pipe. Each shell includes a vent, a drain and fittings for temperature control sensors and is insulated with 3/4 inch equal insulation. Evaporator heaters with thermostat are provided to help protect the evaporator from freezing at ambient temperatures down to -29°C.

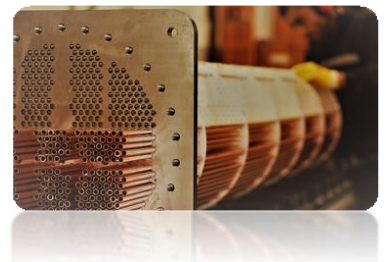

STANDARD SPECIFICATIONS

CONDENSERS COIL

The condenser coils are built up microchannel technology. Integral NOCOLOK brazing low contact resistance improve the heat transfer performance perfectly. AL-AL structure without electric potential difference makes high corrosion resistance. The advantages of microchannel condensers over finned-tube coil are:

- Smaller diameter, more tube holes and larger internal surface intensify unit capacity as per volume.
- Small cross sectional area makes low air flow resistance, small eddy area and low noise.
- Parallel arrangement of flat tubes enlarge refrigerant circulation area.
- Adjusting the position and quantity of baffles to adapt to refrigerant phase transition and optimize heat transfer and pressure drop.
- The structure effectively breaks air thermal boundary layer, reducing heat exchanging resistance.
- Waving path makes the contacts longer to intensify heat exchanging.

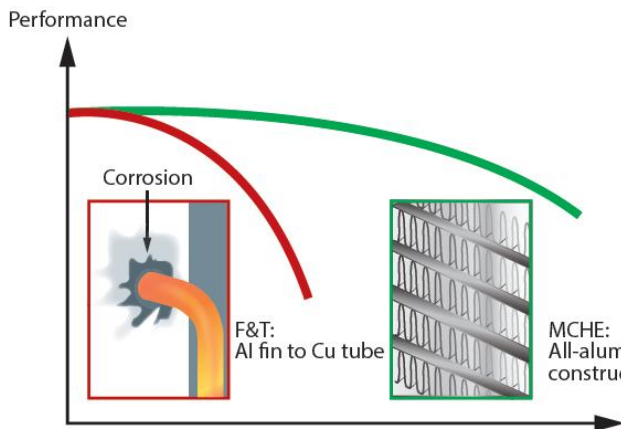
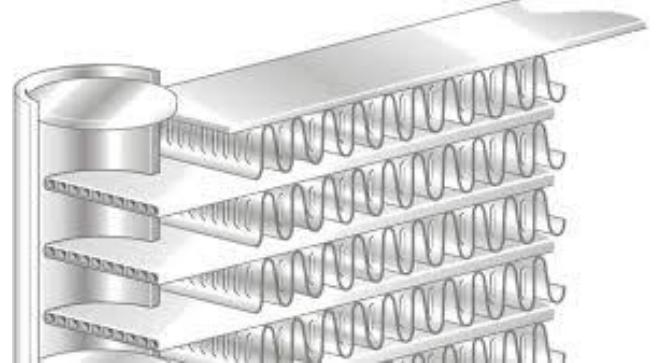
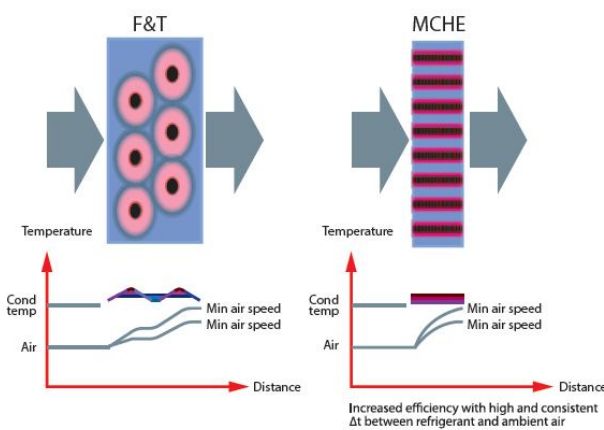

F&T
dust removal difficult - heat transfer loss
high risk of damage during cleaning

MCHE
dust removal easy
immediate performance recovery

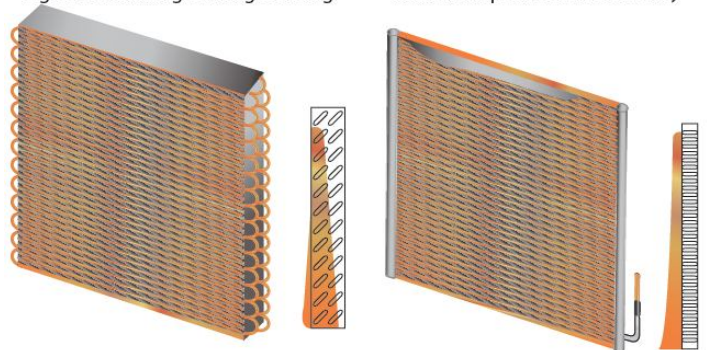

STANDARD SPECIFICATIONS

CONDENSER FAN

Direct drive vertical discharge condenser fans are dynamically balanced. Totally enclosed air over motors completely seal the motor windings to prevent exposure to ambient conditions. Three-phase condenser fan motors with permanently lubricated ball bearings and internal thermal overload protection are provided. Improved acoustic performance due to an optimized blade-design external rotor motors comply with protection class IP54. The winding insulation corresponds to insulation class F. Through the use of deep groove ball bearings, closed on both sides, with specially paired grease lubricant, maintenance-free and low-noise operation is guaranteed.



CONTROL PANEL

Chillers are equipped with a latest version of controller designed to ensure energy saving and unit efficiency. Available functions :

- Monitoring operating parameters including water inlet and outlet temperature, suction and discharge temperature, suction and discharge pressure
- Protecting the system from frosting water
- Stepped or stepless Capacity control
- Controlling Fan start/stop with pressure
- Adjusting Fan speed through controlling inverter (as per request)
- Connection to building Management System (BMS) via MODBUS protocol
- keeping all the faults in the alarm history
- Compressors hour equalization

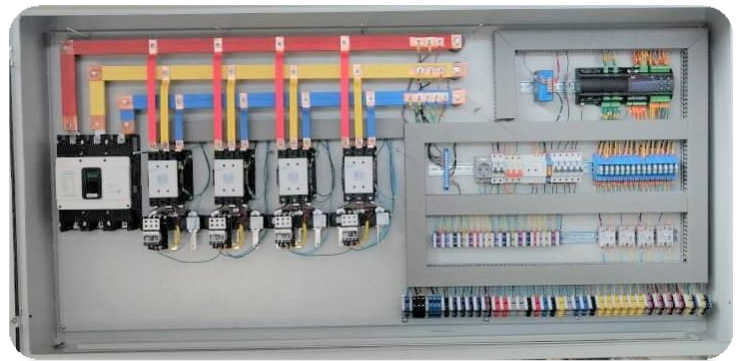

STANDARD SPECIFICATIONS

REFRIGERATION PIPE LINE

- INDEPENDENT REFRIGERATION CIRCUIT PER COMPRESSOR
- ELECTRONIC EXPANSION VALVE: Used to regulate the refrigerant flow to the evaporator and maintain a constant superheat and provide capacity required.
- LIQUID LINE REPLACEABLE CORE TYPE FILTER DRIER: Refrigerant circuits are kept free of harmful moisture, sludge, acids and oil contaminating particles by the filter drier.



- LIQUID LINE MOISTURE INDICATOR SIGHT GLASS: Installed in the liquid line. An easy-to-read color indicator shows moisture contents and provides a mean for checking the system refrigerant charge.
- LIQUID,DISCHARGE AND SUCTION LINES SHUT OFF VALVE
- DISCHARGE, SUCTION AND LIQUID LINE PIPES: All pipelines are sized to minimize pressure drop and keep proper velocity ensuring oil return.
- LIQUID INJECTION KIT: For cooling the compressor in high compressor discharge temperature.

STANDARD SPECIFICATIONS

ELECTRICAL PANEL

- COMPRESSOR PART WINDING START
- COMPRESSOR IN-BUILT PROTECTION DEVICE
- STARTER: The starter is operated by the control circuit and provides power to the compressor motors. These devices are rated to handle safely both RLA and LRA of motors.
- CRANKCASE HEATERS: Each compressor has immersion type crankcase heater. The compressor crankcase heater is always on when the compressors are de-energized. This protects the system against refrigerant Migration, oil dilution and potential compressor failure.
- HIGH PRESSURE SWITCH: This switch provides an additional safety protection in case of excessive discharge pressure.
- LOW PRESSURE SWITCH: This switch provides an additional safety protection in case of very low suction pressure to avoid water freezing.
- UNIT ON-OFF SWITCH: On Off Switch is provided for manually switching the unit control circuit.
- INDICATOR LIGHTS: LED lights indicates power ON to the units, MENU adjustment and FAULT indications due to trip on safety devices.
- UNDER VOLTAGE AND PHASE PROTECTION: This feature protects the chiller against low incoming voltage as well as single phasing , phase reversal and phase imbalance by de-energizing the control circuit.
- FAN MOTOR CIRCUIT BREAKER: For each pair of condenser fan motor.
- COMPRESSOR CIRCUIT BREAKERS: Protects compressor against overload and short circuit. When tripped, the breaker opens the power supply to the compressor and control circuit through auxiliary contacts. These circuit breakers are provided with thermal adjustable switch for precise overload setting.
- EXTERNAL OVERLOAD RELAY FOR EACH COMPRESSOR
- CONTROL FUSED FOR SHORT CIRCUIT PROTECTION

OPTIONAL FEATURES



- **WATER FLOW SWITCH:** Paddle type field adjustable flow switch for water cooler circuits, Interlock into safety circuits so that the unit will remain off unit water flow is determine.
- **UNIT MOUNTING SPRING ISOLATORS:** This housed spring assemblies have a neoprene friction pad on the bottom to prevent vibration transmission.
- **COMPRESSOR SILENCER BOX:** reduces the compressor operating noise and keeps the compressor clean.
- **COPPER FINS/TUBES CONDENSER COILS:** For seashore salty corrosive environments.
- **PRE-COATED ALUMINUM FINS CONDENSER COILS (MHG):** For seashore or acid corrosive environments.
- **BUILDING MANAGEMENT SYSTEM (BMS):** MODBUS, BACNET, and CANBUS protocol
- **NON-FUSED MAIN DISCONNECT SWITCHES:** De-energize power supply during servicing/repair works as well as with door interlock.
- **EVAORATOR HEATER TAPE:** Prevent freezing up of water on low ambient.
- **GROUND CURRENT PROTECTION:** Additional protection for compressor in the case of abnormal current leakage.

TECHNICAL DATA

UNIT MODEL (EACH)		45	50	55	60	70	80	90	100	115	130	140	150
COOLING CAPACITY*	RT	50.7	50.7	56.2	59.0	72.3	83.8	100.2	100.2	116.7	142.2	142.2	152.8
	kW	177.6	177.6	196.9	206.5	252.9	293.2	350.9	350.9	408.5	497.7	497.7	534.8
POWER INPUT (kW)		45.7	45.7	53.2	57.8	65.1	82.3	91.3	91.3	115.4	129.8	129.8	149.0
TOTAL EER (W/W)		3.3	3.3	3.2	3.2	3.4	3.1	3.3	3.3	3.1	3.3	3.3	3.2
COMPRESSOR		Semi Hermetic Compact Screw											
QUANTITY (No.)		1						2					
OIL GRADE		BSE170 Or Equivalent											
OIL CHARGE PER COMPRESSOR (Liter)		14	14	14	21	21	14	14	14	21	21	21	18
CAPACITY CONTROL (%) (STEPPED)		100-25											
CONDENSER TYPE		MICRO CHANNEL											
CONDENSER QTY (No.)		8	8	8	8	10	12	8	8	8	10	10	10
TOTAL FACE AREA (m ²)		8.0	8.0	8.0	8.0	10.0	12.0	16.0	16.0	16.0	20.0	20.0	20.0
CONDENSER FAN		Propeller Direct Driven , 800mm dia , 920 rpm											
FAN QTY (No.)		4	4	4	4	5	6	8	8	8	10	10	10
AIR FLOW RATE (m ³ /h)		90000	90000	90000	90000	112500	135000	180000	180000	180000	225000	225000	225000
MOTOR POWER FAN (kW)		7.6	7.6	7.6	7.6	9.5	11.4	15.2	15.2	15.2	19	19	19
EVAPORATOR		Direct Expansion Shell & Tube											
EVAPORATOR QTY (No.)		1											
WATER FLOW RATE (m ³ /h)		27.6	27.6	30.6	32.1	39.4	45.6	54.6	54.6	63.6	77.5	77.5	83.2
WATER VOLUME PER COOLER (Liter)		128	128	128	128	172	172	167	167	160	277	277	277
WATER CONNECTION SIZE (IN /OUT) DIAMETER (mm)		125	125	125	125	150	150	150	150	150	150	150	150
EXPANSION VALVE		Electronic											
POWER REQUIREMENT		400V/3PH/50Hz											
REFRIGERATION CIRCUITS (No.)		1						2					
APPROXIMATE WEIGHT (kg)		1341	1341	1346	1651	1927	2226	2540	2540	3180	3605	3605	3625
DIMENSION	HEIGHT (m)	2.59	2.59	2.59	2.59	2.59	2.59	2.59	2.59	2.59	2.59	2.59	2.59
	WIDTH (m)	1.27	1.27	1.27	1.27	1.27	1.27	2.27	2.27	2.27	2.27	2.27	2.27
	LENGTH (m)	3.88	3.88	3.88	3.88	4.85	5.82	3.88	3.88	3.88	4.85	4.85	4.85

*Capacity rating are based on Standard ARI-550/590 conditions of: 35 °C (95 °F) ambient/ 7 °C (44.6 °F) Leaving Chilled Water Temperature / 5 °C (9 °F) Inlet-Outlet Water Temperature Difference/ 0.018 m².°C/kW (0.0001 ft². h. °F /Btu) Fouling Factor

TECHNICAL DATA

UNIT MODEL (EACH)		160	170	180	190	200	220	230	240	250	260	270	280
COOLING CAPACITY*	RT	173.9	173.9	204.9	204.9	204.9	240.7	240.7	240.7	274.1	274.1	274.1	274.1
	kW	608.5	608.5	717.2	717.2	717.2	842.4	842.4	842.4	959.3	959.3	959.3	959.3
POWER INPUT (kW)		167.2	167.2	196.3	196.3	196.3	221.6	221.6	221.6	257.8	257.8	257.8	257.8
TOTAL EER (W/W)		3.2	3.2	3.2	3.2	3.2	3.3	3.3	3.3	3.3	3.3	3.3	3.3
COMPRESSOR		Semi Hermetic Compact Screw											
QUANTITY (No.)		2	2	2	2	2	2	2	2	2	2	2	2
OIL GRADE		BSE170 Or Equivalent											
OIL CHARGE PER COMPRESSOR (Liter)		18	18	29	29	29	29	29	29	29	29	29	29
CAPACITY CONTROL (%) (STEPPED)		100-25											
CONDENSER TYPE		MICRO CHANNEL											
CONDENSER QTY (No.)		12	12	14	14	14	16	16	16	18	18	18	18
TOTAL FACE AREA (m ²)		24.0	24.0	28.0	28.0	28.0	32.0	32.0	32.0	36.0	36.0	36.0	36.0
CONDENSER FAN		Propeller Direct Driven , 800mm dia , 920 rpm											
FAN QTY (No.)		12	12	14	14	14	16	16	16	18	18	18	18
AIR FLOW RATE (m ³ /h)		270000	270000	315000	315000	315000	360000	360000	360000	405000	405000	405000	405000
MOTOR POWER FAN (kW)		22.8	22.8	26.6	26.6	26.6	30.4	30.4	30.4	34.2	34.2	34.2	34.2
EVAPORATOR		Direct Expansion Shell & Tube											
EVAPORATOR QTY (No.)		1											
WATER FLOW RATE (m ³ /h)		94.7	94.7	111.6	111.6	111.6	131.1	131.1	131.1	149.3	149.3	149.3	149.3
WATER VOLUME PER COOLER (Liter)		270	270	240	240	240	470	470	470	440	440	440	440
WATER CONNECTION SIZE (IN/OUT) DIAMETER (mm)		150	150	150	150	150	200	200	200	200	200	200	200
EXPANSION VALVE		Electronic											
POWER REQUIREMENT		400V/3PH/50Hz											
REFRIGERATION CIRCUITS (No.)		2											
APPROXIMATE WEIGHT (kg)		3919	3919	5033	5033	5033	5538	5538	5538	5952	5952	5952	5952
DIMENSION	HEIGHT (m)	2.59	2.59	2.59	2.59	2.59	2.59	2.59	2.59	2.59	2.59	2.59	2.59
	WIDTH (m)	2.27	2.27	2.27	2.27	2.27	2.27	2.27	2.27	2.27	2.27	2.27	2.27
	LENGTH (m)	5.82	5.82	6.79	6.79	6.79	7.76	7.76	7.76	8.73	8.73	8.73	8.73

*Capacity rating are based on Standard ARI-550/590 conditions of: 35 °C (95 °F) ambient/ 7 °C (44.6 °F) Leaving Chilled Water Temperature / 5 °C (9 °F) Inlet-Outlet Water Temperature Difference/ 0.018 m².°C/kW (0.0001 ft². h.°F /Btu) Fouling Factor

TECHNICAL DATA

UNIT MODEL (EACH)		300	320	330	340	350	360	380	400	420	430	440	450
COOLING CAPACITY*	RT	321.6	321.6	341.5	341.5	341.5	372.1	372.1	409.9	481.4	481.4	481.4	481.4
	kW	1125.6	1125.6	1195.1	1195.1	1195.1	1302.5	1302.5	1434.5	1684.8	1684.8	1684.8	1684.8
POWER INPUT (kW)		285.7	285.7	328.0	328.0	328.0	352.2	352.2	392.6	443.2	443.2	443.2	443.2
TOTAL EER (W/W)		3.4	3.4	3.2	3.2	3.2	3.2	3.2	3.2	3.3	3.3	3.3	3.3
COMPRESSOR		Semi Hermetic Compact Screw											
QUANTITY (No.)		2						4					
OIL GRADE		BSE170 Or Equivalent											
OIL CHARGE PER COMPRESSOR (Liter)		29	29	31	31	31	31	31	29	29	29	29	29
CAPACITY CONTROL (%) (STEPPED)		100-25											
CONDENSER TYPE		MICRO CHANNEL											
CONDENSER QTY (No.)		22	22	24	24	24	26	26	28	32	32	32	32
TOTAL FACE AREA (m ²)		44.0	44.0	48.0	48.0	48.0	52.0	52.0	56.0	64.0	64.0	64.0	64.0
CONDENSER FAN		Propeller Direct Driven , 800mm dia , 920 rpm											
FAN QTY (No.)		22	22	24	24	24	26	26	28	32	32	32	32
AIR FLOW RATE (m ³ /h)		495000	495000	540000	540000	540000	585000	585000	630000	720000	720000	720000	720000
MOTOR POWER FAN (kW)		41.8	41.8	45.6	45.6	45.6	49.4	49.4	53.2	60.8	60.8	60.8	60.8
EVAPORATOR		Direct Expansion Shell & Tube											
EVAPORATOR QTY (No.)		1						2					
WATER FLOW RATE (m ³ /h)		175.2	175.2	186.0	186.0	186.0	202.7	202.7	223.3	262.3	262.3	262.3	262.3
WATER VOLUME PER COOLER (Liter)		590	590	590	590	590	550	550	240	470	470	470	470
WATER CONNECTION SIZE (IN/OUT) DIAMETER (mm)		250	250	250	250	250	250	250	150	200	200	200	200
EXPANSION VALVE		Electronic											
POWER REQUIREMENT		400V/3PH/50Hz											
REFRIGERATION CIRCUITS (No.)		2						4					
APPROXIMATE WEIGHT (kg)		6751	6751	7185	7185	7185	7590	7890	9374	10073	10073	10073	10073
DIMENSION	HEIGHT (m)	2.59	2.59	2.59	2.59	2.59	2.59	2.59	2.59	2.59	2.59	2.59	2.59
	WIDTH (m)	2.27	2.27	2.27	2.27	2.27	2.27	2.27	2.27	2.27	2.27	2.27	2.27
	LENGTH (m)	10.67	10.67	11.64	11.64	11.64	12.61	12.61	13.58	15.52	15.52	15.52	15.52

*Capacity rating are based on Standard ARI-550/590 conditions of: 35 °C (95 °F) ambient/ 7 °C (44.6 °F) Leaving Chilled Water Temperature / 5 °C (9 °F) Inlet-Outlet Water Temperature Difference/ 0.018 m².°C/kW (0.0001 ft². h.°F /Btu) Fouling Factor

PERFORMANCE DATA TABLES

LEAVING CHILLED WATER TEMP. (LCWT)	UNIT SIZE	30°C (86°F) AMBIENT TEMPERATURE				
		COOLING CAPACITY		COMP. POWER (kW)	Total EER (W/W)	WATER FLOW (m³/h)
		RT	kW			
7°C	EACH-45	53.3	186.4	42.8	3.7	29
	EACH-50	53.3	186.4	42.8	3.7	29
	EACH-55	59.4	207.7	48.7	3.7	32.3
	EACH-60	62.3	218	52.1	3.7	33.9
	EACH-70	76.3	267.2	59.2	3.9	41.6
	EACH-80	88.9	311.2	75.2	3.6	48.4
	EACH-90	104.9	367.3	85.8	3.6	57.2
	EACH-100	104.9	367.3	85.8	3.6	57.2
	EACH-115	123.4	431.8	104.2	3.6	67.2
	EACH-130	150.2	525.8	118.3	3.8	81.8
	EACH-140	150.2	525.8	118.3	3.8	81.8
	EACH-150	162.2	567.7	133	3.7	88.4
	EACH-160	183.8	643.3	151.4	3.7	100.1
	EACH-170	183.8	643.3	151.4	3.7	100.1
	EACH-180	217.2	760	177.4	3.7	118.3
	EACH-190	217.2	760	177.4	3.7	118.3
	EACH-200	217.2	760	177.4	3.7	118.3
	EACH-220	254.6	891.2	201	3.9	138.7
	EACH-230	254.6	891.2	201	3.9	138.7
	EACH-240	254.6	891.2	201	3.9	138.7
	EACH-250	289.7	1014.1	230.8	3.8	157.9
	EACH-260	289.7	1014.1	230.8	3.8	157.9
	EACH-270	289.7	1014.1	230.8	3.8	157.9
	EACH-280	289.7	1014.1	230.8	3.8	157.9
	EACH-300	338.1	1183.4	261	3.9	184.2
	EACH-320	338.1	1183.4	261	3.9	184.2
	EACH-330	359.9	1259.5	301	3.6	196.1
	EACH-340	359.9	1259.5	301	3.6	196.1
	EACH-350	359.9	1259.5	301	3.6	196.1
	EACH-360	391.9	1371.7	321.5	3.7	213.5
EACH-380	391.9	1371.7	321.5	3.7	213.5	
EACH-400	434.3	1520.1	354.7	3.7	236.6	
EACH-420	509.2	1782.3	402.1	3.9	277.4	
EACH-430	509.2	1782.3	402.1	3.9	277.4	
EACH-440	509.2	1782.3	402.1	3.9	277.4	
EACH-450	509.2	1782.3	402.1	3.9	277.4	

1- ECHA Chillers are rated based on Standard ARI-550/590-98 conditions of: 5 °C (9 °F) Inlet/Outlet Water Temperature Difference and 0.018 m²·°C/kW (0.0001 ft²· h·°F /Btu) Fouling Factor

2- Direct interpolation is permissible. Do not extrapolate.

3- Energy Efficiency Ratio (EER) is for the overall unit, refer to electrical data for fan power input.

PERFORMANCE DATA TABLES

LEAVING CHILLED WATER TEMP. (LCWT)	UNIT SIZE	35°C (95°F) AMBIENT TEMPERATURE				
		COOLING CAPACITY		COMP. POWER (kW)	Total EER (W/W)	WATER FLOW (m³/h)
		RT	kW			
7°C	EACH-45	50.7	177.6	45.7	3.3	27.6
	EACH-50	50.7	177.6	45.7	3.3	27.6
	EACH-55	56.2	196.9	53.2	3.2	30.6
	EACH-60	59	206.5	57.8	3.2	32.1
	EACH-70	72.3	252.9	65.1	3.4	39.4
	EACH-80	83.8	293.2	82.3	3.1	45.6
	EACH-90	100.2	350.9	91.3	3.3	54.6
	EACH-100	100.2	350.9	91.3	3.3	54.6
	EACH-115	116.7	408.5	115.4	3.1	63.6
	EACH-130	142.2	497.7	129.8	3.3	77.5
	EACH-140	142.2	497.7	129.8	3.3	77.5
	EACH-150	152.8	534.8	149	3.2	83.2
	EACH-160	173.9	608.5	167.2	3.2	94.7
	EACH-170	173.9	608.5	167.2	3.2	94.7
	EACH-180	204.9	717.2	196.3	3.2	111.6
	EACH-190	204.9	717.2	196.3	3.2	111.6
	EACH-200	204.9	717.2	196.3	3.2	111.6
	EACH-220	240.7	842.4	221.6	3.3	131.1
	EACH-230	240.7	842.4	221.6	3.3	131.1
	EACH-240	240.7	842.4	221.6	3.3	131.1
	EACH-250	274.1	959.3	257.8	3.3	149.3
	EACH-260	274.1	959.3	257.8	3.3	149.3
	EACH-270	274.1	959.3	257.8	3.3	149.3
	EACH-280	274.1	959.3	257.8	3.3	149.3
	EACH-300	321.6	1125.6	285.7	3.4	175.2
	EACH-320	321.6	1125.6	285.7	3.4	175.2
	EACH-330	341.5	1195.1	328	3.2	186
	EACH-340	341.5	1195.1	328	3.2	186
	EACH-350	341.5	1195.1	328	3.2	186
	EACH-360	372.1	1302.5	352.2	3.2	202.7
EACH-380	372.1	1302.5	352.2	3.2	202.7	
EACH-400	409.9	1434.5	392.6	3.2	223.3	
EACH-420	481.4	1684.8	443.2	3.3	262.3	
EACH-430	481.4	1684.8	443.2	3.3	262.3	
EACH-440	481.4	1684.8	443.2	3.3	262.3	
EACH-450	481.4	1684.8	443.2	3.3	262.3	

1- ECHA Chillers are rated based on Standard ARI-550/590-98 conditions of: 5 °C (9 °F) Inlet/Outlet Water Temperature Difference and 0.018 m².°C/kW (0.0001 ft². h.°F /Btu) Fouling Factor

2- Direct interpolation is permissible. Do not extrapolate.

3- Energy Efficiency Ratio (EER) is for the overall unit, refer to electrical data for fan power input.

PERFORMANCE DATA TABLES

LEAVING CHILLED WATER TEMP. (LCWT)	UNIT SIZE	40°C (104°F) AMBIENT TEMPERATURE				
		COOLING CAPACITY		COMP. POWER (kW)	Total EER (W/W)	WATER FLOW (m ³ /h)
		RT	kW			
7°C	EACH-45	47.9	167.5	50	2.9	26.1
	EACH-50	47.9	167.5	50	2.9	26.1
	EACH-55	53	185.4	58.3	2.8	28.9
	EACH-60	55.6	194.7	63.7	2.7	30.3
	EACH-70	67.9	237.5	71.6	2.9	37
	EACH-80	78.5	274.7	90.3	2.7	42.8
	EACH-90	94.6	331.1	99.9	2.9	51.5
	EACH-100	94.6	331.1	99.9	2.9	51.5
	EACH-115	110.1	385.2	127	2.7	60
	EACH-130	133.7	468	142.8	2.9	72.8
	EACH-140	133.7	468	142.8	2.9	72.8
	EACH-150	143.8	503.4	164.1	2.7	78.4
	EACH-160	163.8	573.4	184.1	2.8	89.3
	EACH-170	163.8	573.4	184.1	2.8	89.3
	EACH-180	192.7	674.5	215.2	2.8	105
	EACH-190	192.7	674.5	215.2	2.8	105
	EACH-200	192.7	674.5	215.2	2.8	105
	EACH-220	226.6	793.2	240.6	2.9	123.5
	EACH-230	226.6	793.2	240.6	2.9	123.5
	EACH-240	226.6	793.2	240.6	2.9	123.5
	EACH-250	259.2	907.2	282.7	2.9	141.2
	EACH-260	259.2	907.2	282.7	2.9	141.2
	EACH-270	259.2	907.2	282.7	2.9	141.2
	EACH-280	259.2	907.2	282.7	2.9	141.2
	EACH-300	303.8	1063.4	315.2	3	165.5
	EACH-320	303.8	1063.4	315.2	3	165.5
	EACH-330	322.7	1129.5	356.9	2.8	175.8
	EACH-340	322.7	1129.5	356.9	2.8	175.8
	EACH-350	322.7	1129.5	356.9	2.8	175.8
	EACH-360	352.1	1232.4	384	2.8	191.8
EACH-380	352.1	1232.4	384	2.8	191.8	
EACH-400	385.4	1349	430.4	2.8	210	
EACH-420	453.3	1586.5	481.1	2.9	246.9	
EACH-430	453.3	1586.5	481.1	2.9	246.9	
EACH-440	453.3	1586.5	481.1	2.9	246.9	
EACH-450	453.3	1586.5	481.1	2.9	246.9	

1- ECHA Chillers are rated based on Standard ARI-550/590-98 conditions of: 5 °C (9 °F) Inlet/Outlet Water Temperature Difference and 0.018 m².°C/kW (0.0001 ft². h.°F /Btu) Fouling Factor

2- Direct interpolation is permissible. Do not extrapolate.

3- Energy Efficiency Ratio (EER) is for the overall unit, refer to electrical data for fan power input.

PERFORMANCE DATA TABLES

LEAVING CHILLED WATER TEMP. (LCWT)	UNIT SIZE	45°C (113°F) AMBIENT TEMPERATURE				
		COOLING CAPACITY		COMP. POWER (kW)	Total EER (W/W)	WATER FLOW (m³/h)
		RT	kW			
7°C	EACH-45	44.8	156.7	55.1	2.5	24.4
	EACH-50	44.8	156.7	55.1	2.5	24.4
	EACH-55	49.5	173.2	64.3	2.4	27
	EACH-60	52.2	182.7	70.4	2.3	28.4
	EACH-70	63.4	221.8	79.1	2.5	34.5
	EACH-80	72.9	255.3	99.4	2.3	39.7
	EACH-90	88.6	310	110	2.5	48.3
	EACH-100	88.6	310	110	2.5	48.3
	EACH-115	103.3	361.6	140.6	2.3	56.3
	EACH-130	124.8	436.9	157.8	2.5	68
	EACH-140	124.8	436.9	157.8	2.5	68
	EACH-150	134.6	471.1	181.4	2.4	73.3
	EACH-160	153.5	537.2	203.8	2.4	83.6
	EACH-170	153.5	537.2	203.8	2.4	83.6
	EACH-180	180.1	630.2	236.7	2.4	98.1
	EACH-190	180.1	630.2	236.7	2.4	98.1
	EACH-200	180.1	630.2	236.7	2.4	98.1
	EACH-220	212	741.9	262.8	2.5	115.5
	EACH-230	212	741.9	262.8	2.5	115.5
	EACH-240	212	741.9	262.8	2.5	115.5
	EACH-250	243.7	853	309.7	2.5	132.8
	EACH-260	243.7	853	309.7	2.5	132.8
	EACH-270	243.7	853	309.7	2.5	132.8
	EACH-280	243.7	853	309.7	2.5	132.8
	EACH-300	285.8	1000.4	346	2.6	155.7
	EACH-320	285.8	1000.4	346	2.6	155.7
	EACH-330	302.9	1060.1	389	2.4	165
	EACH-340	302.9	1060.1	389	2.4	165
	EACH-350	302.9	1060.1	389	2.4	165
	EACH-360	329	1151.7	427.3	2.4	179.3
EACH-380	329	1151.7	427.3	2.4	179.3	
EACH-400	360.1	1260.4	473.5	2.4	196.2	
EACH-420	423.9	1483.8	525.5	2.5	231	
EACH-430	423.9	1483.8	525.5	2.5	231	
EACH-440	423.9	1483.8	525.5	2.5	231	
EACH-450	423.9	1483.8	525.5	2.5	231	

1- ECHA Chillers are rated based on Standard ARI-550/590-98 conditions of: 5 °C (9 °F) Inlet/Outlet Water Temperature Difference and 0.018 m²·°C/kW (0.0001 ft²· h·°F /Btu) Fouling Factor

2- Direct interpolation is permissible. Do not extrapolate.

3- Energy Efficiency Ratio (EER) is for the overall unit, refer to electrical data for fan power input.

PERFORMANCE DATA TABLES

LEAVING CHILLED WATER TEMP. (LCWT)	UNIT SIZE	50°C (122°F) AMBIENT TEMPERATURE				
		COOLING CAPACITY		COMP. POWER (kW)	Total EER (W/W)	WATER FLOW (m ³ /h)
		RT	kW			
7°C	EACH-45	41.6	145.6	61.1	2.1	22.7
	EACH-50	41.6	145.6	61.1	2.1	22.7
	EACH-55	45.8	160.3	71.4	2	25
	EACH-60	48.6	170.2	78.3	2	26.5
	EACH-70	58.9	206	87.8	2.1	32.1
	EACH-80	67.3	235.6	109.5	1.9	36.7
	EACH-90	82.2	287.6	122	2.1	44.8
	EACH-100	82.2	287.6	122	2.1	44.8
	EACH-115	96.2	336.7	156.3	2	52.4
	EACH-130	116	406	175.1	2.1	63.2
	EACH-140	116	406	175.1	2.1	63.2
	EACH-150	125.2	438.3	201.5	2	68.2
	EACH-160	142.8	499.9	226.4	2	77.8
	EACH-170	142.8	499.9	226.4	2	77.8
	EACH-180	166.8	584	260	2	90.9
	EACH-190	166.8	584	260	2	90.9
	EACH-200	166.8	584	260	2	90.9
	EACH-220	197.3	690.5	288.1	2.2	107.5
	EACH-230	197.3	690.5	288.1	2.2	107.5
	EACH-240	197.3	690.5	288.1	2.2	107.5
	EACH-250	227.6	796.6	339.2	2.1	124
	EACH-260	227.6	796.6	339.2	2.1	124
	EACH-270	227.6	796.6	339.2	2.1	124
	EACH-280	227.6	796.6	339.2	2.1	124
	EACH-300	267.3	935.4	379.5	2.2	145.6
	EACH-320	267.3	935.4	379.5	2.2	145.6
	EACH-330	282.5	988.7	424.7	2.1	153.9
	EACH-340	282.5	988.7	424.7	2.1	153.9
	EACH-350	282.5	988.7	424.7	2.1	153.9
	EACH-360	309.7	1083.9	460.2	2.1	168.7
EACH-380	309.7	1083.9	460.2	2.1	168.7	
EACH-400	333.7	1167.9	520	2	181.8	
EACH-420	394.6	1381.1	576.3	2.2	215	
EACH-430	394.6	1381.1	576.3	2.2	215	
EACH-440	394.6	1381.1	576.3	2.2	215	
EACH-450	394.6	1381.1	576.3	2.2	215	

1- ECHA Chillers are rated based on Standard ARI-550/590-98 conditions of: 5 °C (9 °F) Inlet/Outlet Water Temperature Difference and 0.018 m².°C/kW (0.0001 ft². h.°F /Btu) Fouling Factor

2- Direct interpolation is permissible. Do not extrapolate.

3- Energy Efficiency Ratio (EER) is for the overall unit, refer to electrical data for fan power input.

UNIT DIMENSIONS

EACH 45-50-55-60

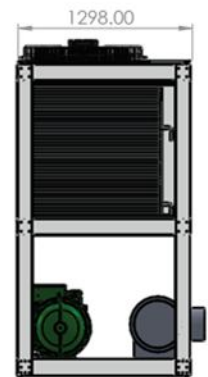
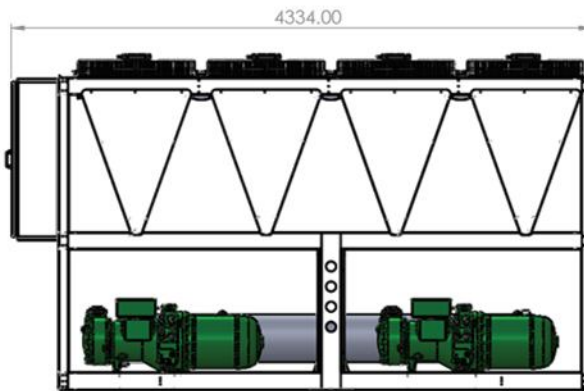
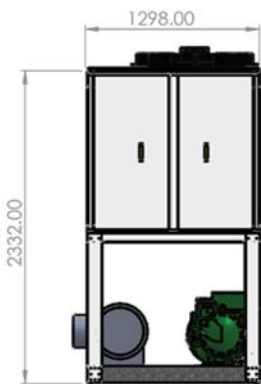
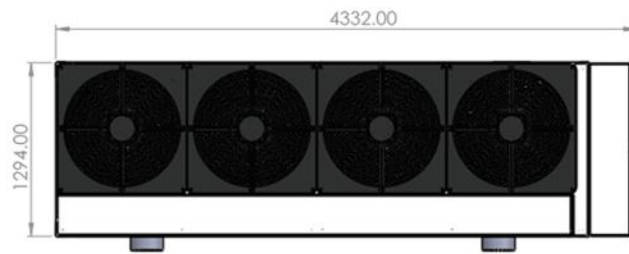
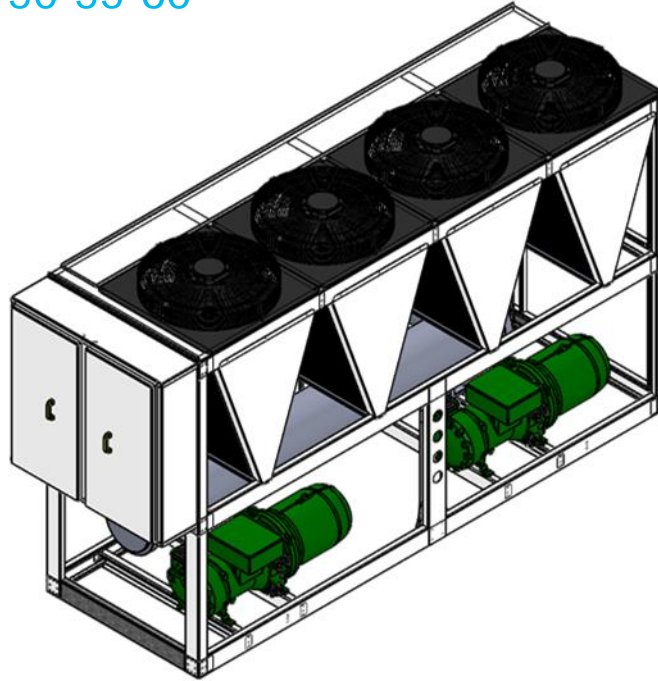

UNIT DIMENSIONS

EACH 70

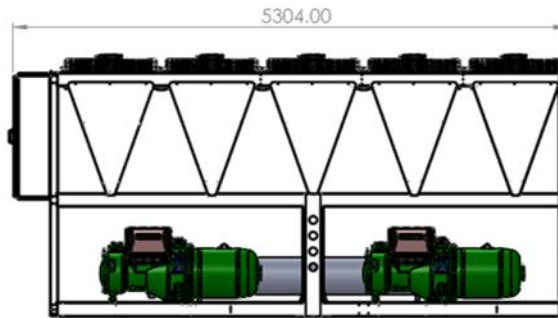
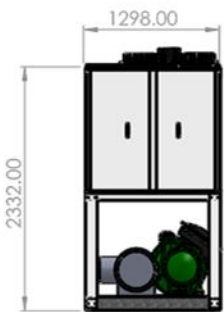
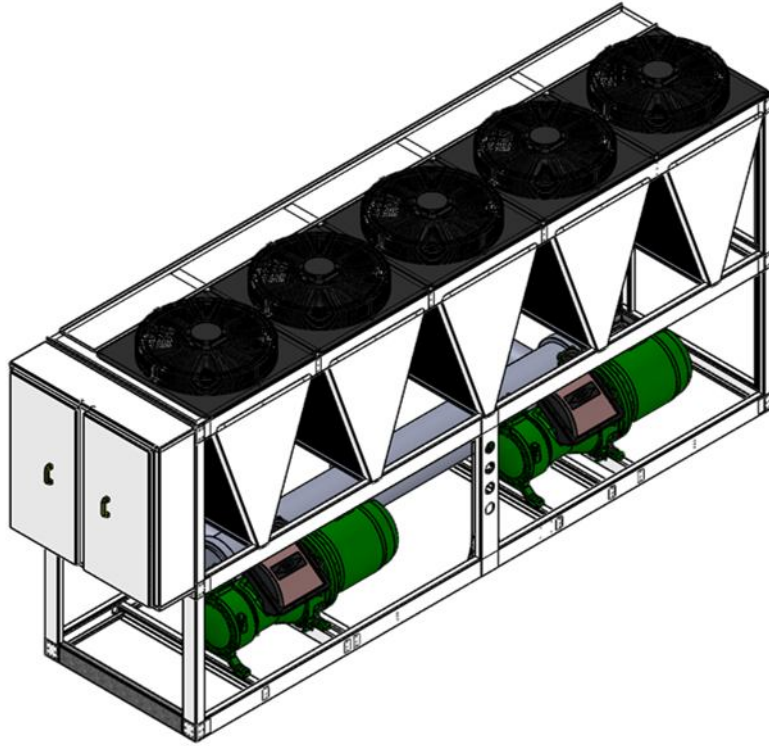

UNIT DIMENSIONS

EACH 80

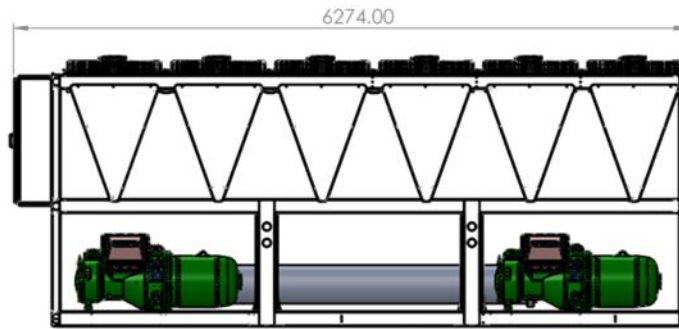
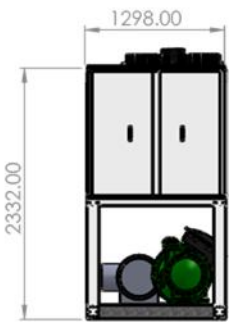
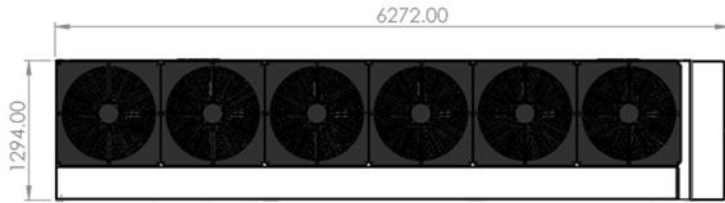
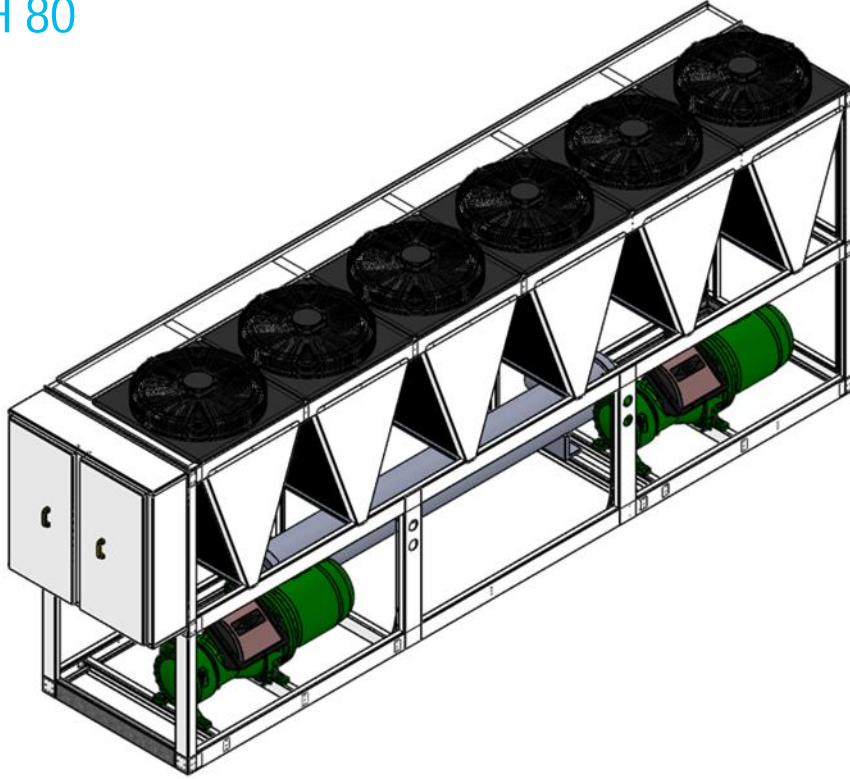

UNIT DIMENSIONS

EACH 90-100-115

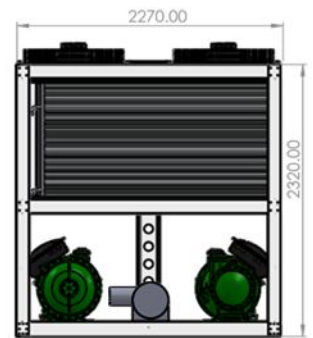
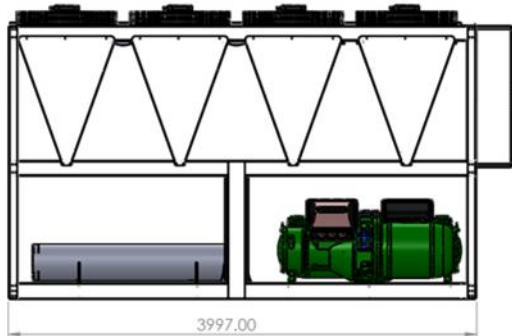
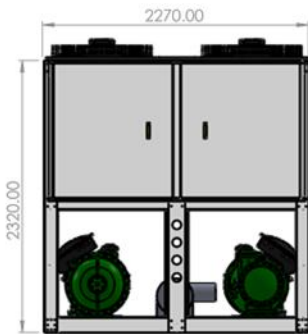
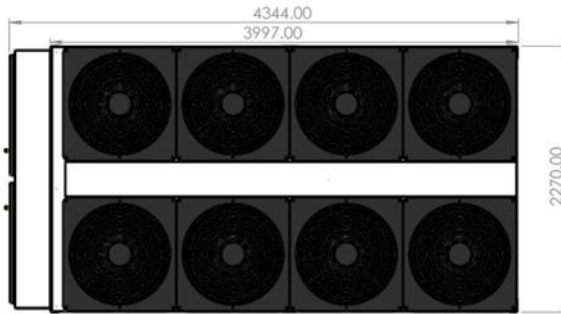
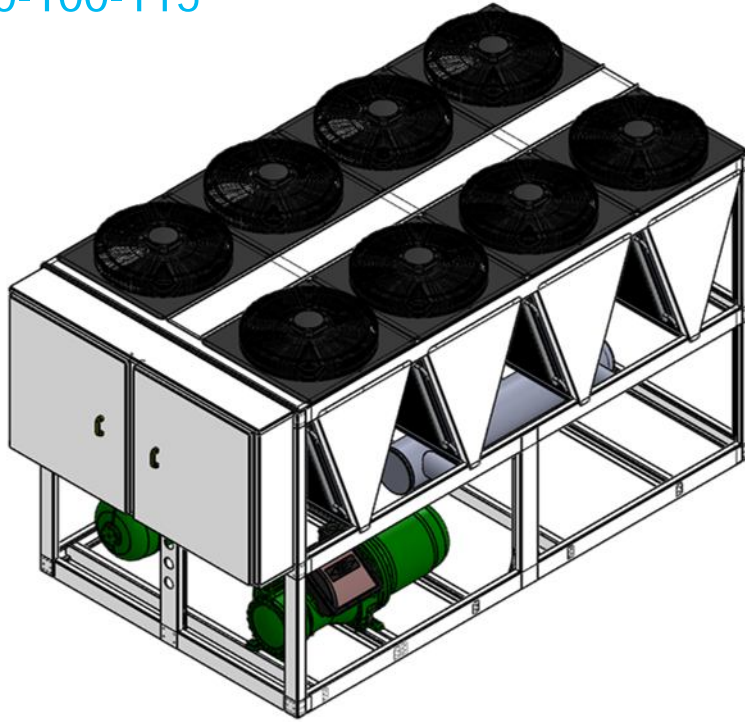

UNIT DIMENSIONS

EACH 130-140-150

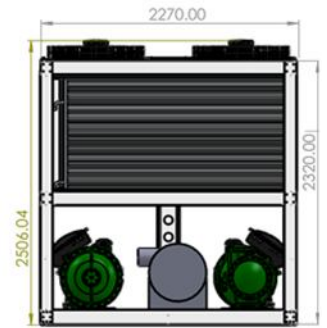
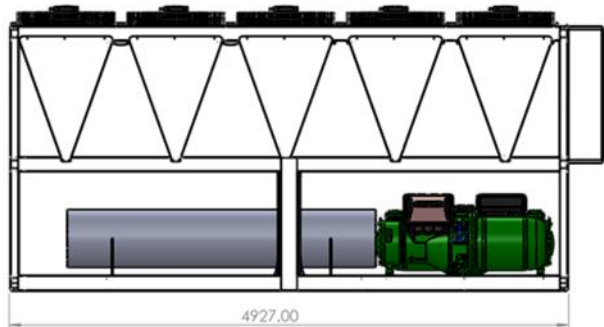
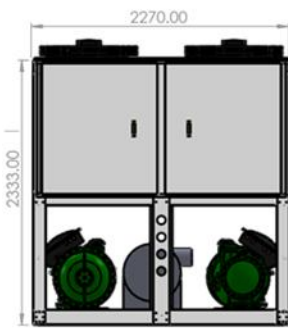
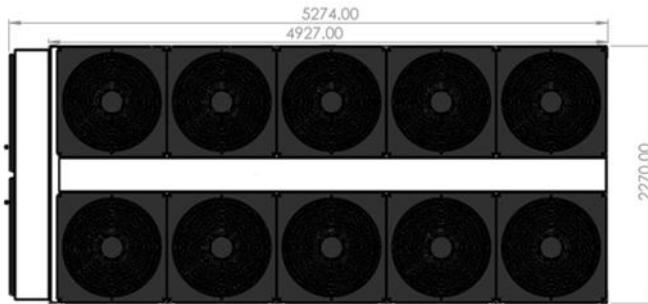
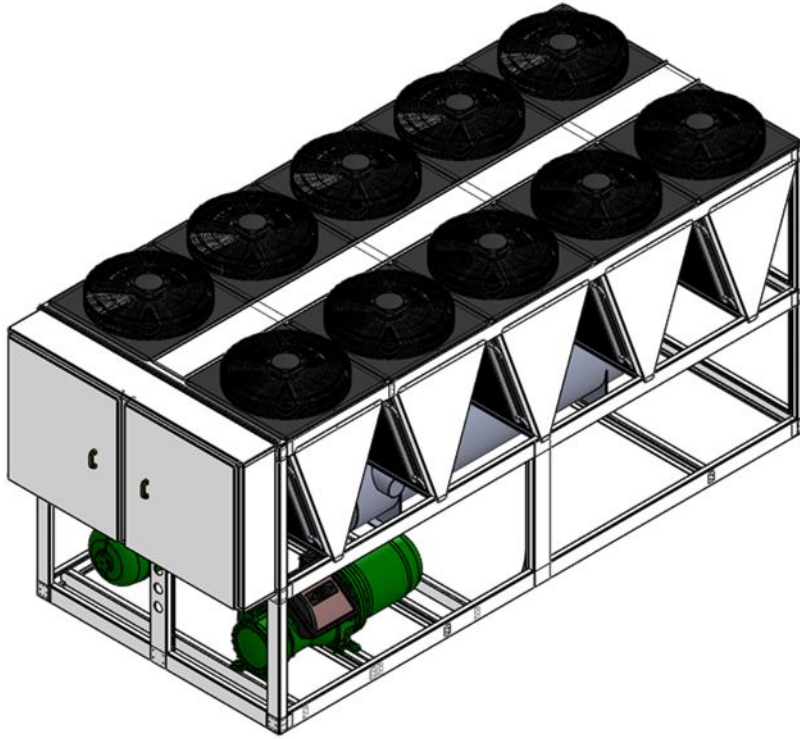

UNIT DIMENSIONS

EACH 160-170

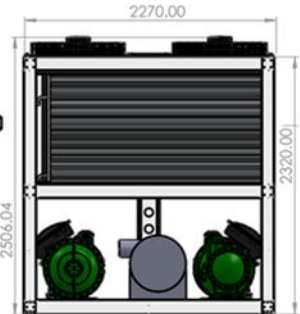
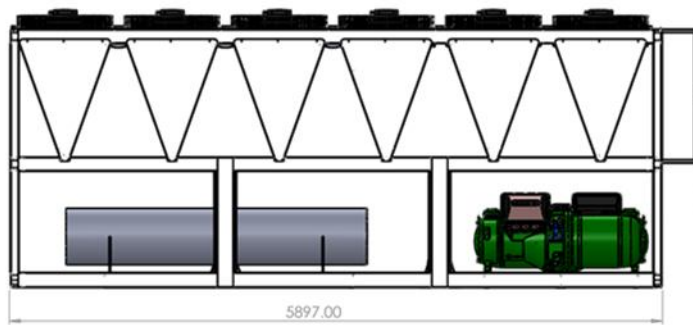
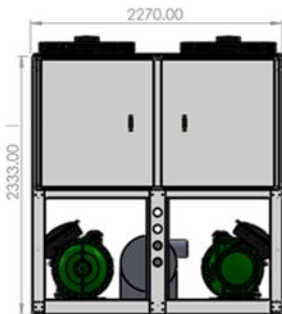
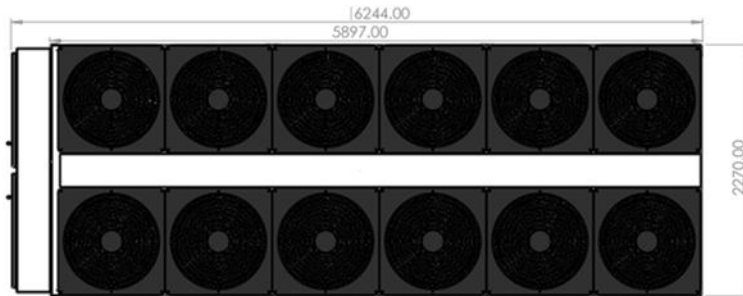
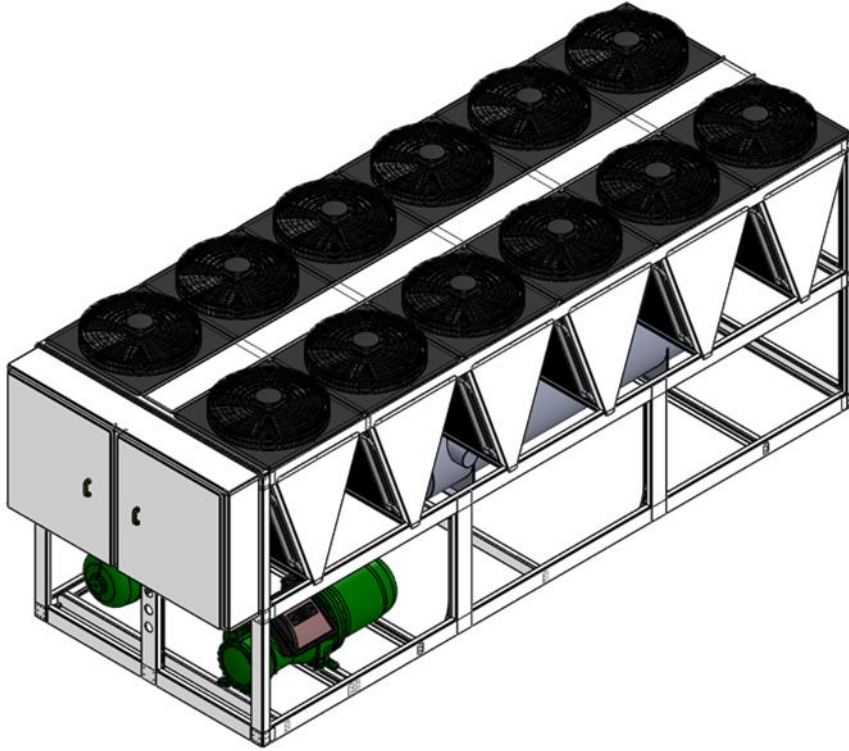

UNIT DIMENSIONS

EACH 180-190-200

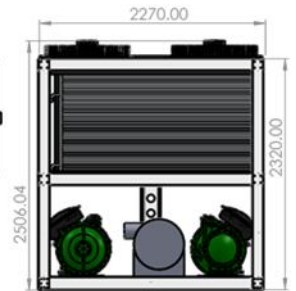
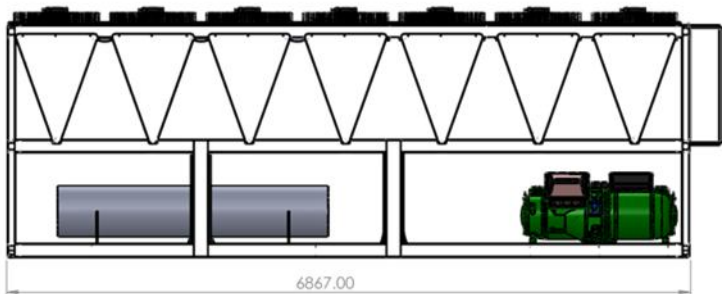
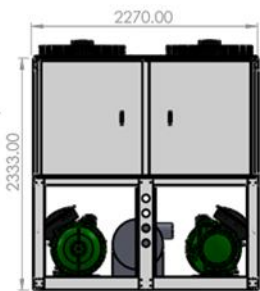
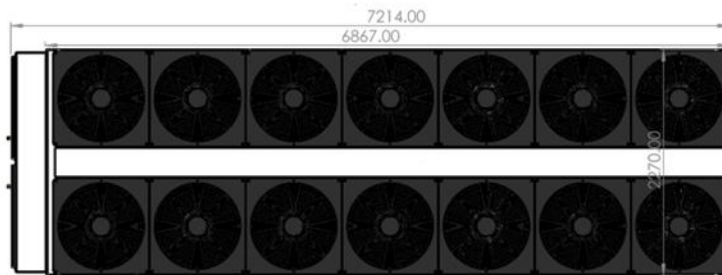
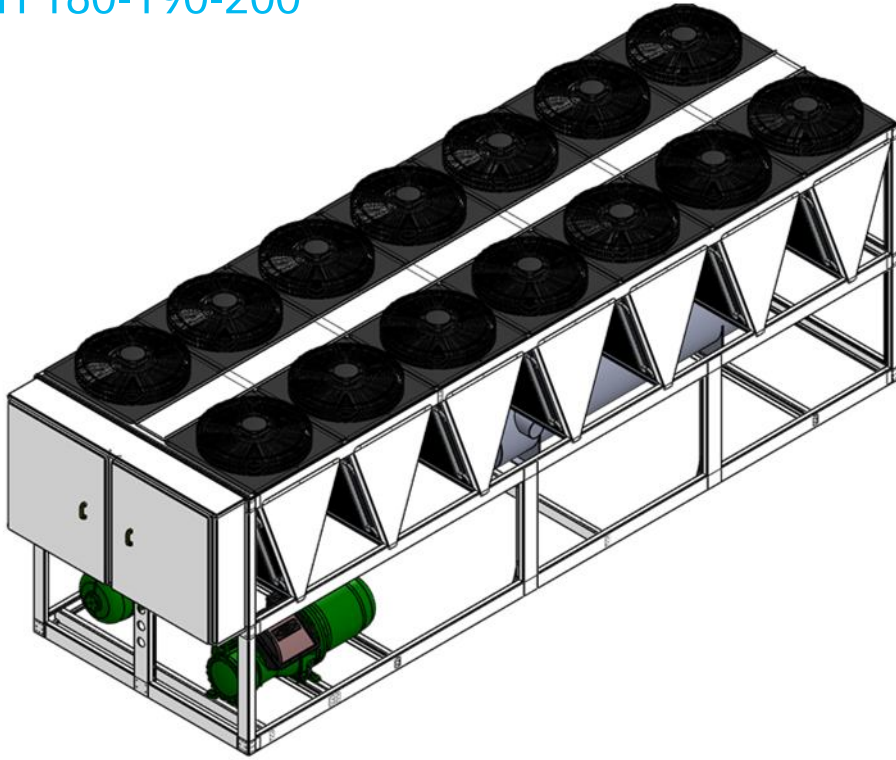

UNIT DIMENSIONS

EACH 220-230-240

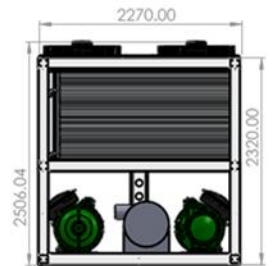
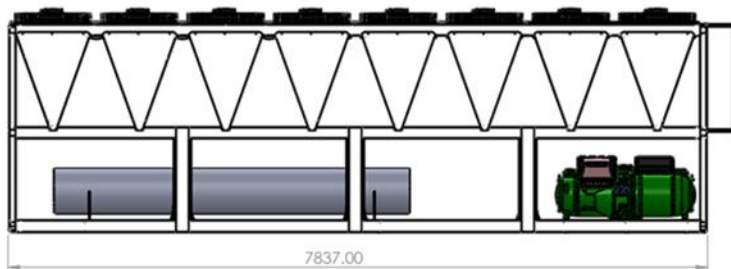
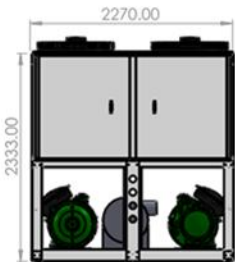
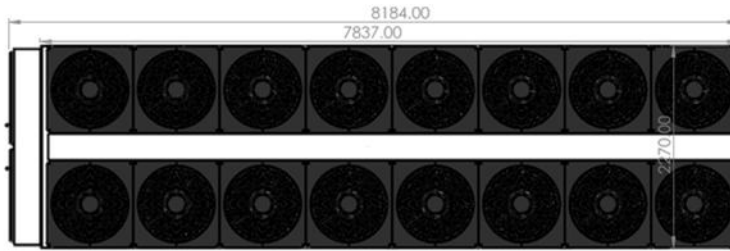
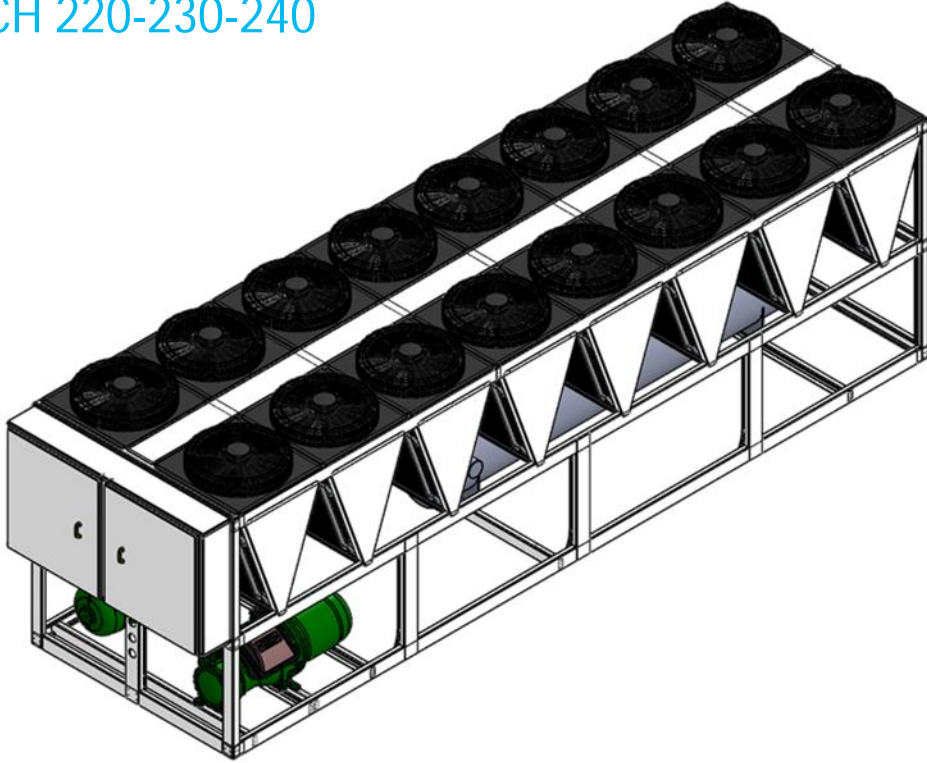

UNIT DIMENSIONS

EACH 250-260-270-280

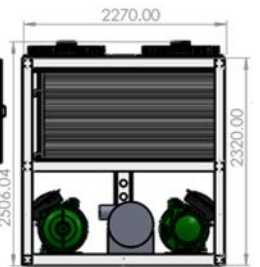
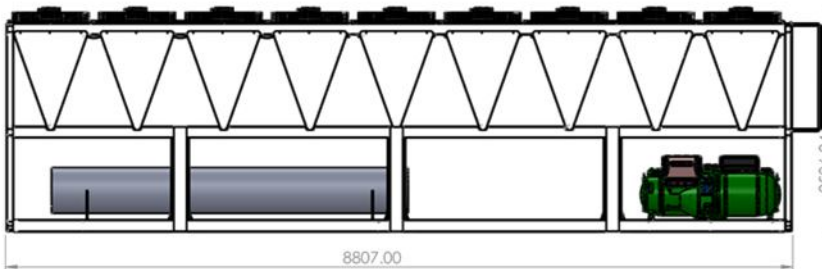
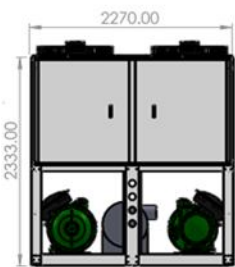
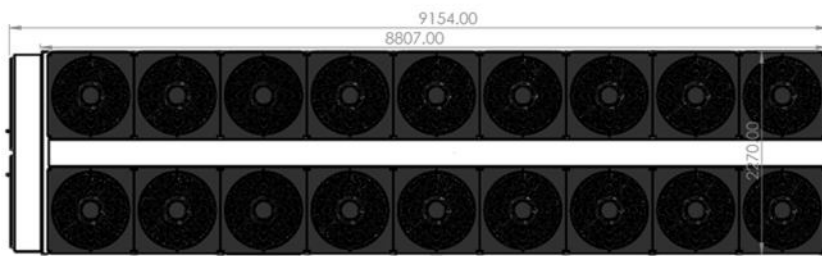
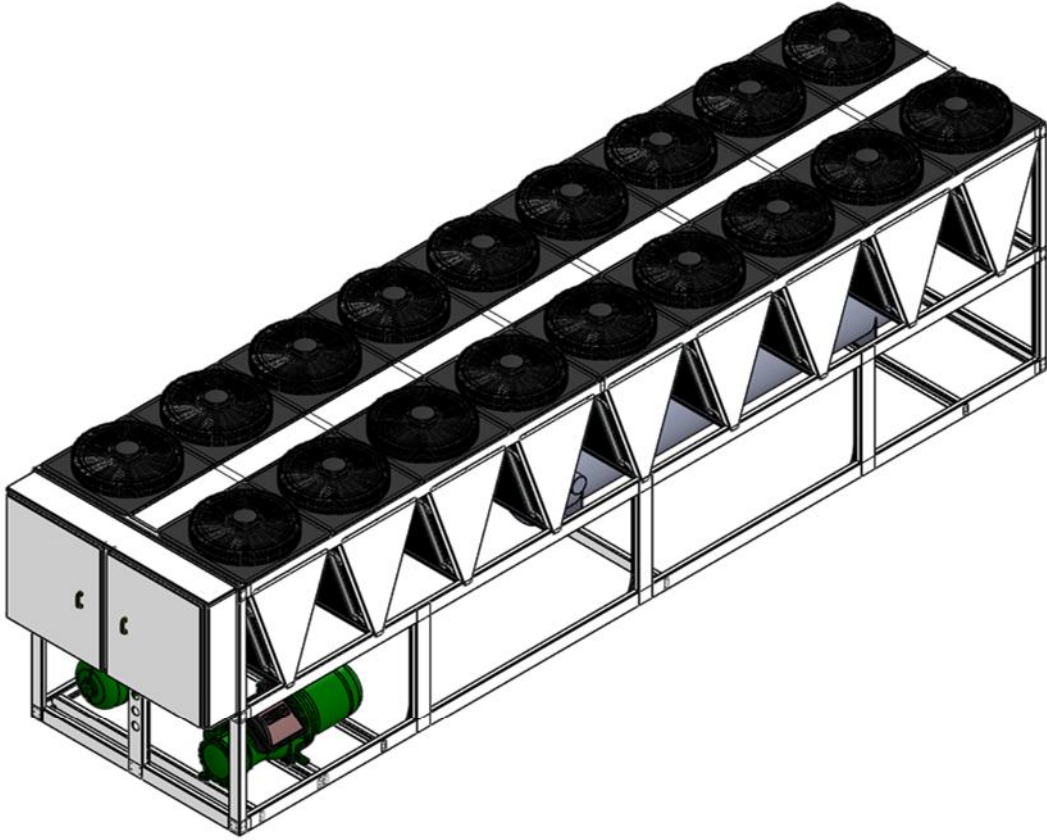

UNIT DIMENSIONS

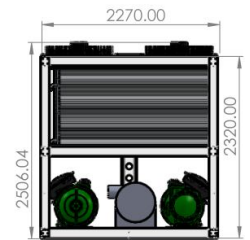
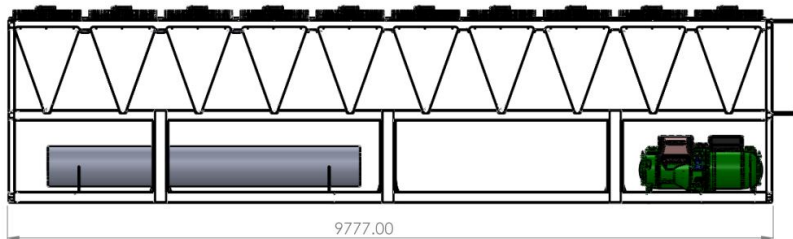
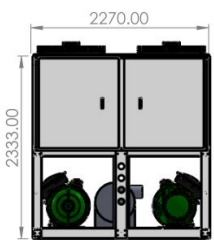
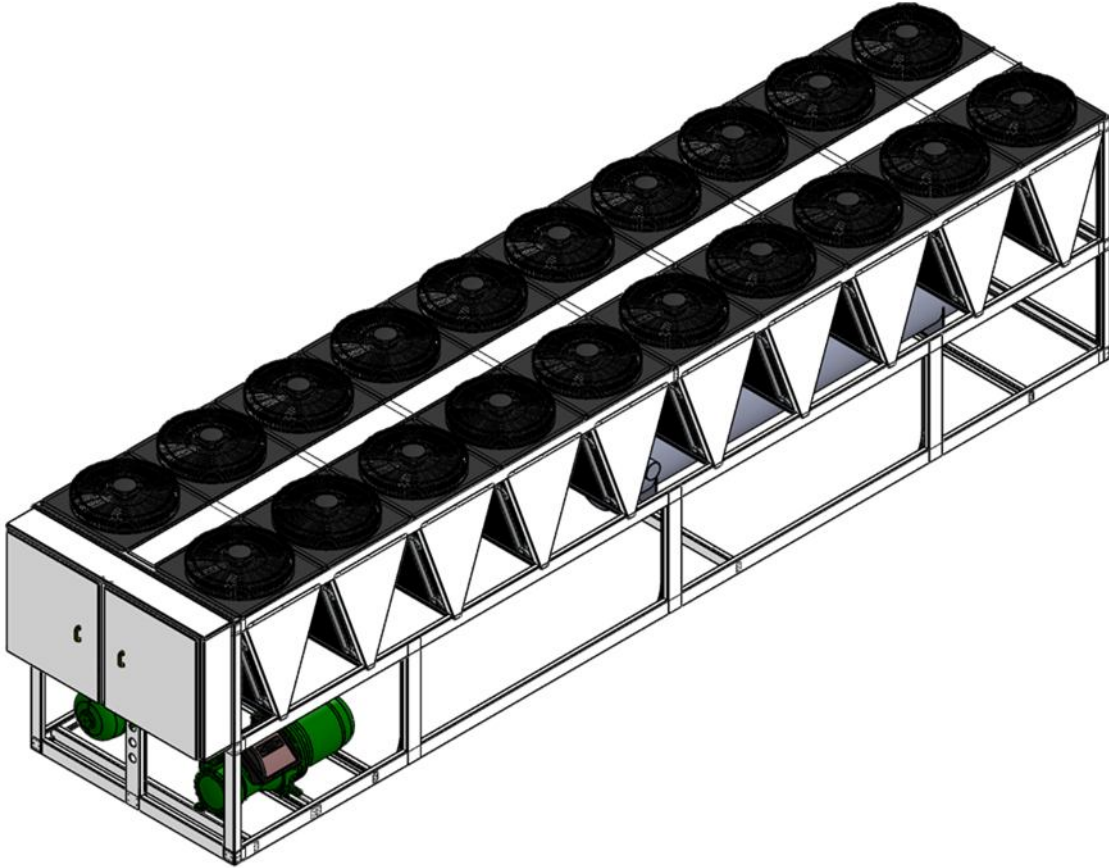

UNIT DIMENSIONS

EACH 300-320

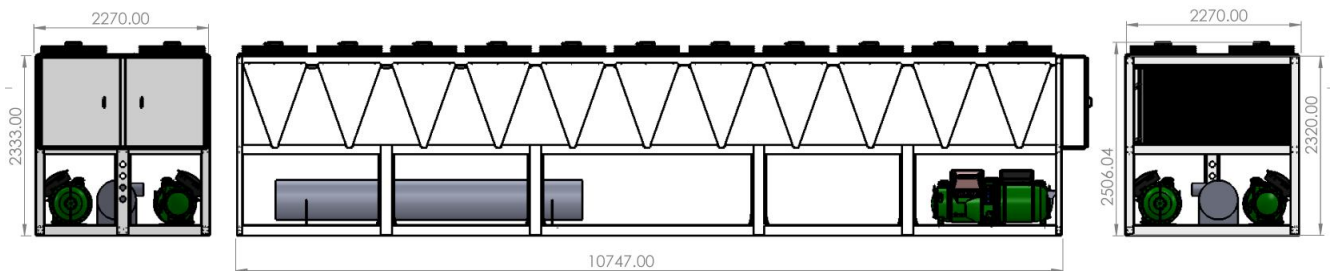
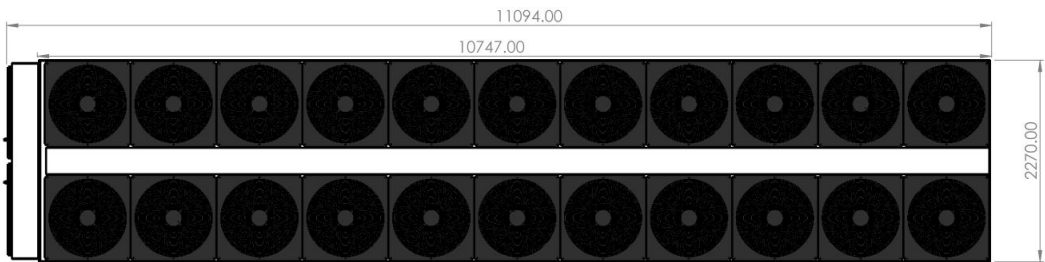
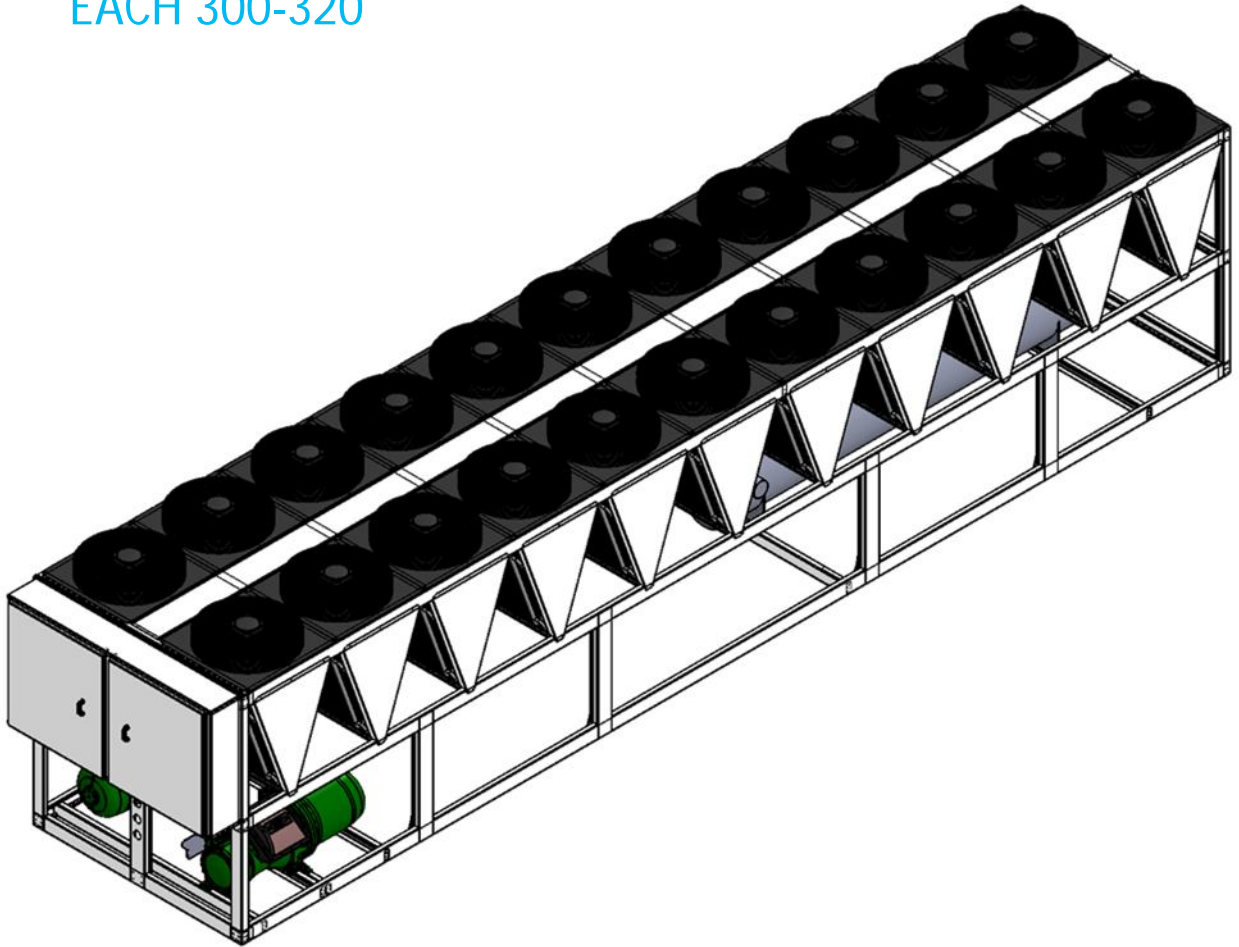

UNIT DIMENSIONS

EACH 330-340-350

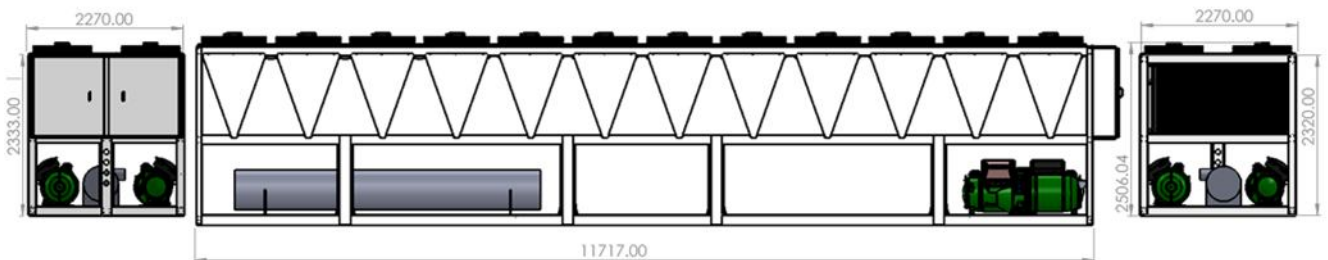
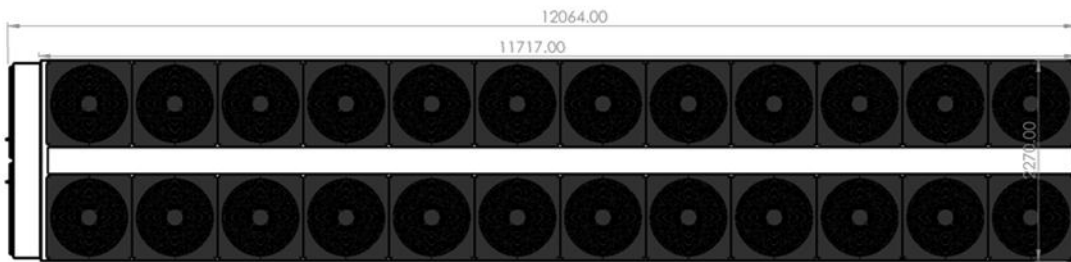
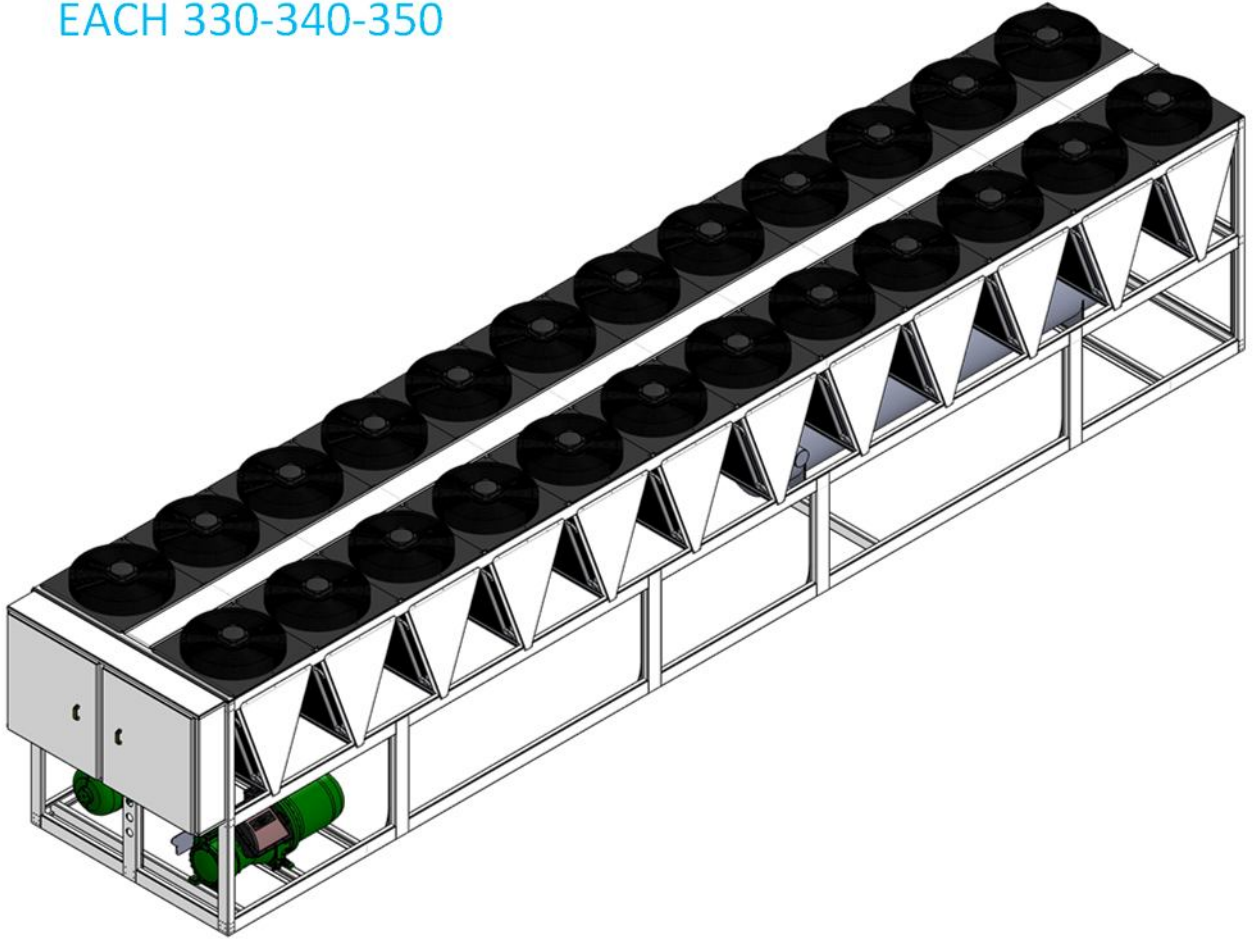

Typical electrical wiring diagram

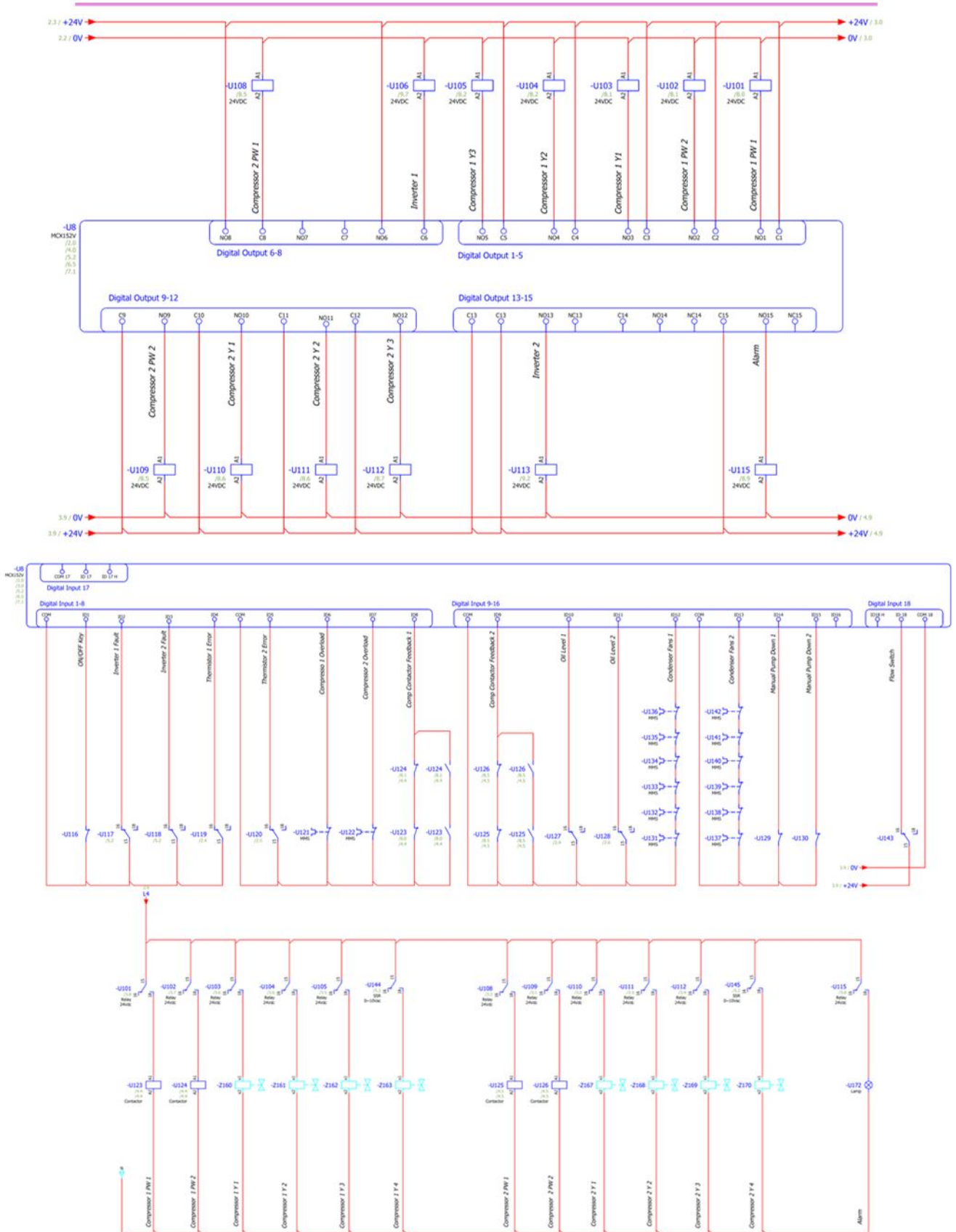

TYPICAL WIRING DIAGRAM

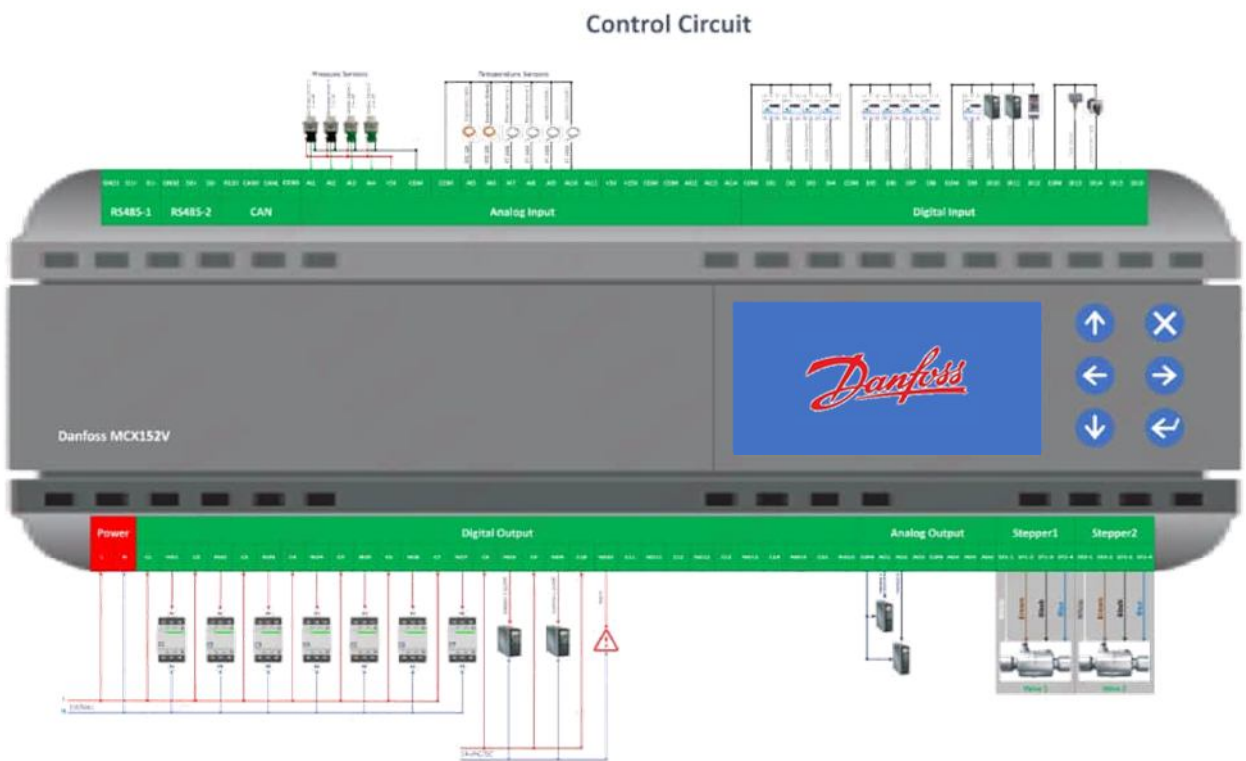

Power Circuit





. NOTE .

A large rectangular area with rounded corners, outlined in light blue, containing numerous horizontal light blue lines for writing. The lines are evenly spaced and cover the majority of the page below the header.

ECO COOLER
AIR CONDITIONER